

The Effectiveness of Exhaust Fan Rotation with Microcontroller for Indoor CO₂ Gas Concentration Control System

Sri Hartanto^{1,*}, Tri Ongko Priyono¹ and Triono²

¹*Department of Electrical Engineering, Universitas Krisnadwipayana, Jakarta, Indonesia*

²*Research and Development Department, PT Delamita Bilano, Jakarta, Indonesia*

**Corresponding Author: srihartanto@unkris.ac.id*

(Received 09-02-2023; Revised 26-02-2023; Accepted 27-02-2023)

Abstract

A dangerous gas that is harmful to human health and is generally found in the room is carbon dioxide (CO₂) gas, which is produced from the accumulation of cigarette smoke. In order to overcome the CO₂ gas concentration in the room, it is necessary to develop a device that can control the CO₂ gas concentration in the room and that processes the CO₂ gas detection results from the MQ-2 sensor. In this research, a device simulation was created that can control the CO₂ gas concentration produced by accumulated cigarette smoke in a simulation room measuring 15 cm long, 20 cm wide, and 15 cm high with two CO₂ gas release ventilation holes, each with a diameter of 3.5 cm, using the exhaust fan rotation and a microcontroller type Arduino UNO as the control unit. The effectiveness of using a microcontroller of the type Arduino UNO to process the CO₂ gas detection results from the MQ-2 sensor can be seen in how the exhaust fan works to release CO₂ gas from the simulation room. From the results of this research, it can be seen that the effectiveness of the exhaust fan rotation in controlling the CO₂ gas concentration detected by the MQ-2 sensor looks good where the CO₂ gas concentration can be controlled under 350 ppm.

Keywords: CO₂ gas; cigarette smoke; microcontroller; exhaust fan rotation, MQ-2 sensor

1 Introduction

The health of people is impacted by air quality. Cigarette smoke is one of the many elements that can lower air quality [1]. The primary component of cigarette smoke is a particle that is less than 1 micron in size, and it could even be as small as 0.1 micron [2]. The smoke inhalation cycle follows a recognizable rhythm that includes a puff, smoke inhalation, and smoke expiration [3].



IoT becomes a utility as sensing, actuation, communications, control, and knowledge extraction from massive amounts of data grow more sophisticated [4]. Data will be gathered, exchanged, and analyzed by IoT to get important knowledge about the interactions between things [5, 6]. The IoT's fundamental components include sensors and actuators [7, 8] to control systems [9]. The control unit shows the smoke unit in the display area receives a signal from the smoke detector when it detects smoke within the house [10]. One sensor that can find CO₂ gas is the MQ series gas sensor [11]. MQ-2 was chosen because, in addition to its high sensitivity, it is inexpensive and suitable for a wide range of applications [12]. The MQ-2 gas sensor has the ability to detect gas leakage such as LPG, i-butane, methane, alcohol, hydrogen, smoke, etc. [13]. The gas sensor will be configured via Open CR like a microcontroller of the type Arduino UNO [14]. The microcontroller of the type Arduino UNO program was created utilizing this smoke sensor input to determine the presence of cigarette smoke [15]. The microcontroller of the type Arduino UNO serves as the controller and signal processor for the MQ-2 sensor that detects cigarette smoke [16, 17].

Therefore, in this research, a device simulation was created that can control the CO₂ gas concentration produced by accumulated cigarette smoke in the room using the exhaust fan rotation and a microcontroller type Arduino UNO as the control unit. The indoor CO₂ gas control system is simulated in the room measuring 15 cm long, 20 cm wide, and 15 cm high with two CO₂ gas release ventilation holes, each with a diameter of 3.5 cm, wherein the CO₂ gas concentration from cigarette smoke is gradually increased by lighting one to five cigarettes. This research is expected to determine the effectiveness of exhaust fan rotation in controlling the CO₂ gas concentration detected by the MQ-2 sensor.

2 Research Methodology

This research was conducted in several phases, as seen in Figure 1, as follows:

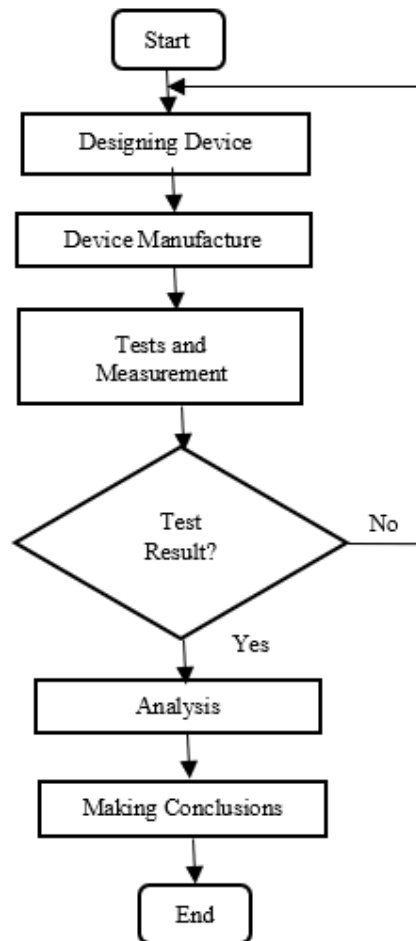

Figure 1. Flowchart of Research Method

The method used in this research refers to a sequential algorithm, where the research steps are carried out sequentially [18, 19, 20]. The research begins by collecting data on the components that make up the device used to examine controlling system the CO₂ gas concentration to detect cigarette smoke in a room. In this step, the research was carried out by designing an indoor CO₂ gas concentration control circuit with the MQ-2 sensor using QElectroTech software, which was then controlled by the microcontroller of the type Arduino UNO version 1.6.11 microcontroller and issued an electrical voltage used to drive the exhaust fan and display a warning on the LCD display screen. The block diagram of the indoor CO₂ gas concentration control circuit design is shown in Figure 2. Then, those processing results are used to adjust the exhaust fan rotation.

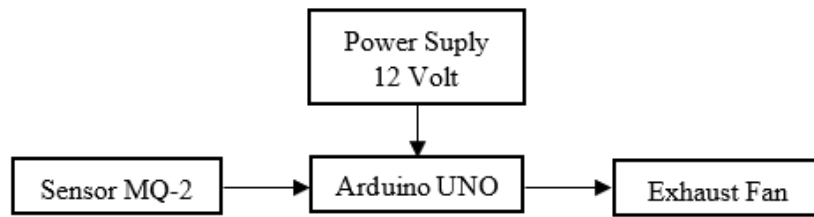

Figure 2. Circuit Block Diagram

The design of an indoor CO₂ gas control system consists of two steps, namely the design of the electronic circuit (hardware) and the design of the microcontroller program (software). The design of an electronic circuit for controlling CO₂ gas in a room using the MQ-2 sensor and exhaust fan rotation made using the QElectroTech software is shown in Figure 3. The MQ-2 sensor [21, 22, 23] will send a signal to the microcontroller of the type Arduino UNO via pin A0, when the MQ-2 sensor detects cigarette smoke. The data from the MQ-2 sensor is then processed by the microcontroller of the type Arduino UNO. When the microcontroller of the type Arduino UNO processes, the voltage data from the MQ-2 sensor is transmitted to pin A0. The results of data processing will be displayed on the LCD and run the exhaust fan at medium and high conditions. As a display of smoke conditions, the LCD display will display the specified conditions. As shown in Figure 3, to display smoke conditions on the LCD using pins 12, 11, 10, 9, 8, 7 of a microcontroller of the type Arduino UNO. The LED connected to pins 4, 5, 6 of a microcontroller of the type Arduino UNO will turn on according to the conditions that have been determined. The exhaust fan rotation release smoke to the outer room.

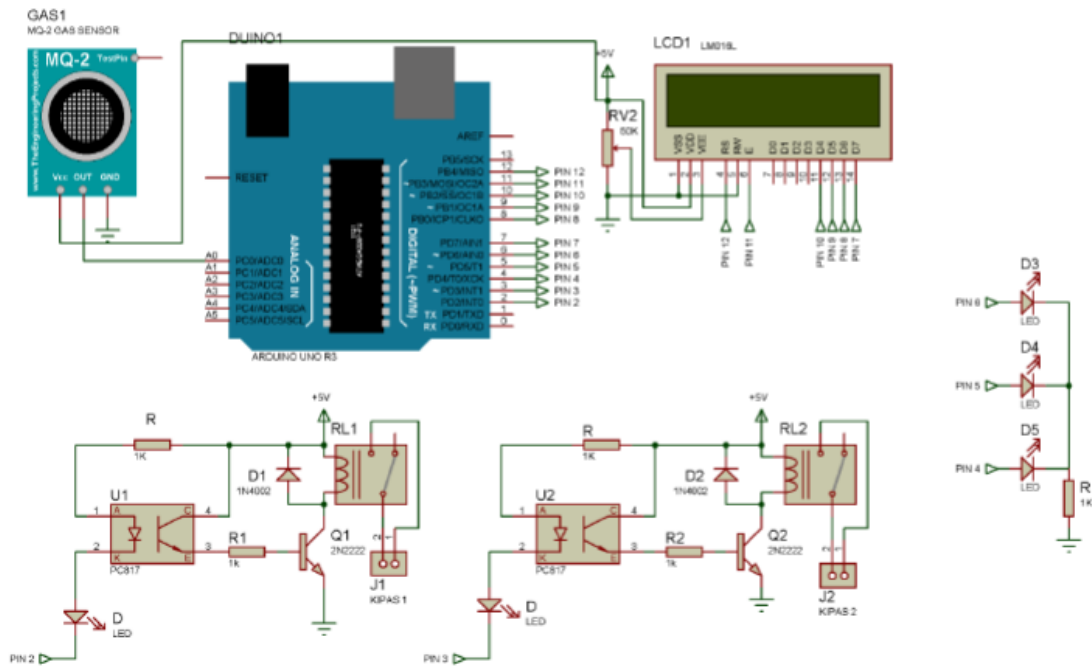

Figure 3. Electronic Circuit Design

In the device manufacture step, the layout of the PCB [26] for the design of an electronic indoor CO₂ gas concentration control device is made in accordance with the component diagram contained in the electronic indoor CO₂ gas concentration control circuit, which includes the constituent components that connect the MQ-2 sensor, the microcontroller of the type Arduino UNO circuit, and an output device in the form of an LCD display panel and an exhaust fan. The circuit that has been made is then put into a simulation room made of mica with a length x width x height of 15 cm x 20 cm x 15 cm. Finally, the microcontroller of the type Arduino UNO is programmed using the microcontroller of the type Arduino UNO IDE software version 1.6.11 [24, 25]. The embodiment of the electronic circuit design for indoor CO₂ gas concentration control device can be seen in Figure 4.

In the tests and measurement step, the MQ-2 sensor-equipped indoor CO₂ gas concentration control device is tested, and its output is controlled and measured using a measuring device such as a multimeter. Cigarettes, from one to five that are burned simultaneously, are burned in order to measure the operation of the MQ-2 sensor and

exhaust fan. The output on the LCD is then scrutinized to ascertain the MQ-2 sensor's sensitivity to detecting cigarette smoke. The exhaust fan's inlet and outlet voltage were then controlled to determine how well it worked to clear the room of cigarette smoke.

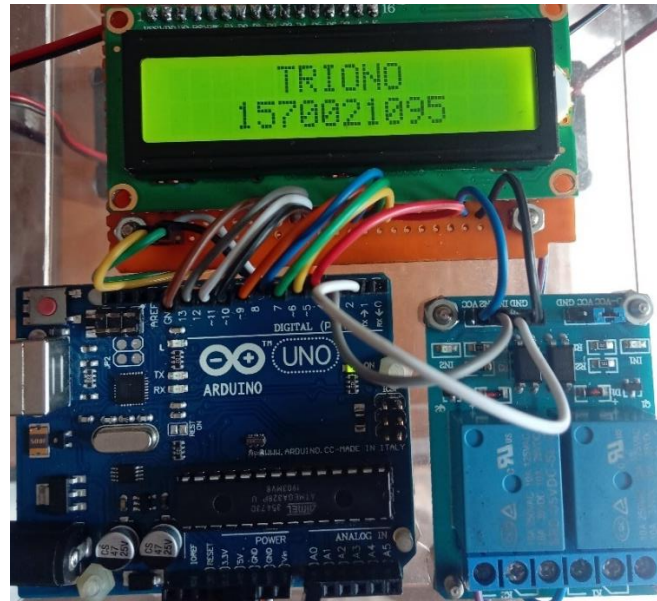

Figure 4. Indoor CO₂ Gas Concentration Control Device

In the analysis step, from the results of observations and performance measurements of the indoor CO₂ gas concentration control device with the MQ-2 sensor, it is analyzed to know the effectiveness of exhaust fan rotation in controlling the CO₂ gas concentration detected by the MQ-2 sensor.

In the final step, conclusions are made from the analysis of performance measurements of the indoor CO₂ gas concentration control device with the MQ-2 sensor.

3 Results and Discussions

The process of detecting smoke using the MQ-2 sensor which is shown in Figure 5. First, the device is turned on. The next step is initialization, which involves checking the readiness of the program and device system circuits. Furthermore, the MQ-2 sensor detects cigarette smoke, which is then transmitted to the Arduino UNO microcontroller for processing and sends an output signal to the output devices, LCD screen, LED light, and the exhaust fan. When the MQ-2 sensor output is less than 1 volt (< 1 V), the Arduino

UNO microcontroller will turn on the green LED light and LCD Display shows "Low". When the MQ-2 sensor output is greater than 1 volt and less than 3 volt ($1\text{ V} < \text{MQ-2 sensor output} < 3\text{ V}$), the Arduino UNO microcontroller will turn off the green LED light, turn on the yellow LED light, turn on the exhaust fan 1 and LCD Display shows "Medium". When the MQ-2 sensor output is greater than 3 volt ($> 3\text{ V}$), the Arduino UNO microcontroller will turn off the yellow LED light, turn on the red LED light, turn on the exhaust fan 1 and 2 and LCD Display shows "High" (in this condition, both the exhaust fan will turn on).

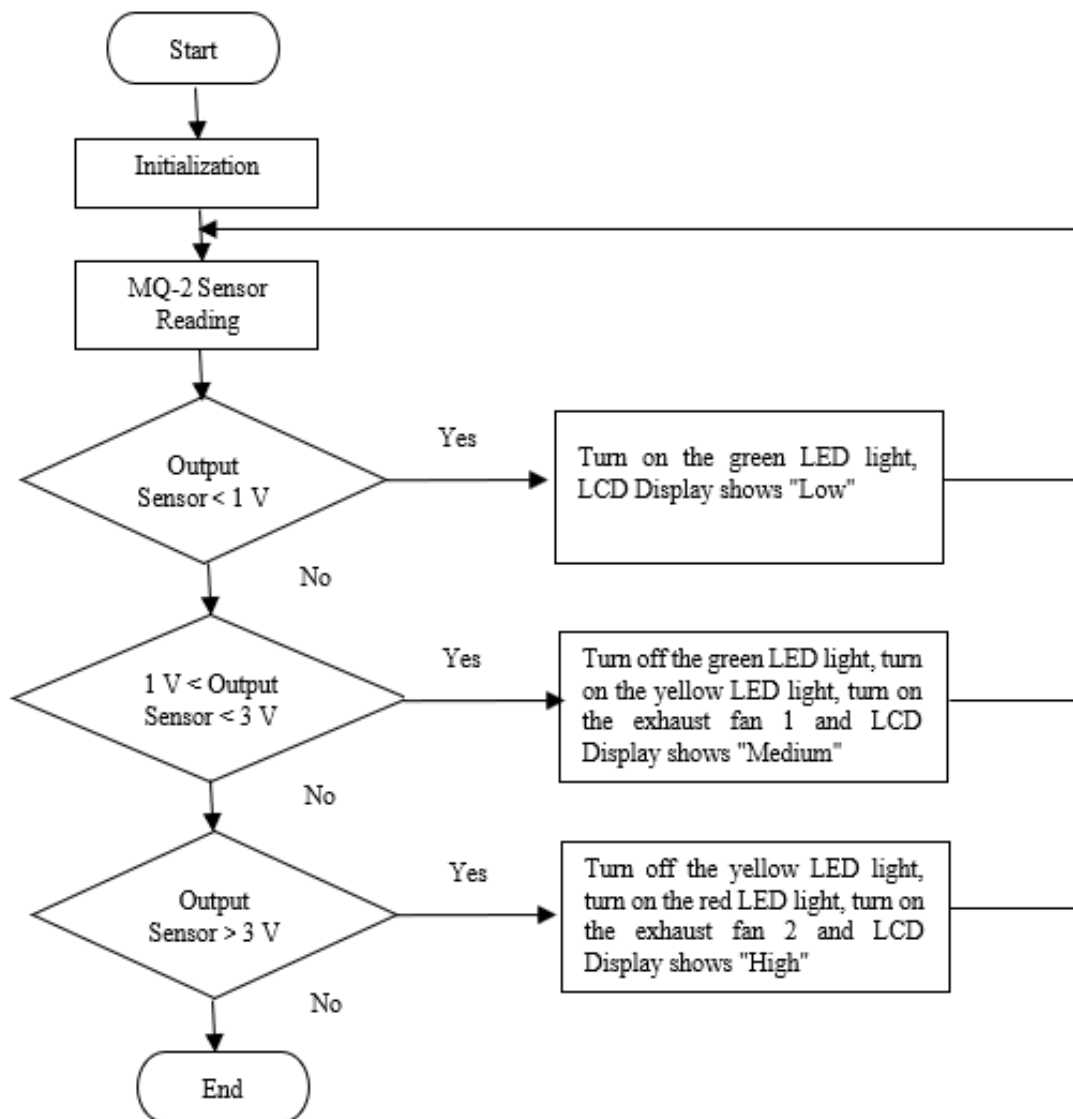

Figure 5. Process of Detecting Smoke Using the MQ-2 Sensor

Overall circuit testing in the design of this device as shown in Figure 6 ensure the equipment functions as designed. First, testing the whole circuit starts with the MQ-2 sensor sending a signal to the microcontroller if it detects smoke. When the Arduino UNO microcontroller gets a signal from the MQ-2 smoke sensor, it will process the program and send signals to the LEDs and relays. The relay will connect the exhaust fan to the electric current so that the exhaust fan rotates when the Arduino UNO microcontroller sends a low, medium, or high condition signal. The LED will turn on when it gets a signal from the microcontroller. The LCD will display the voltage value from the MQ-2 smoke sensor and the condition if it gets a signal from the Arduino UNO microcontroller.



Figure 6. Indoor CO₂ Gas Control System Test

The sequence of steps for the LED lighting condition described as follows. The first step of testing a cigarette smoke detection device is to burn one cigarette with a length of 80 mm and a diameter of 7 mm, which is placed on an ashtray and put into the simulation room. At the beginning of the experiment, before the sixth minute, the LED lights off and the LCD display does not display smoke condition information. In the sixth minute, the green LED lights up and the LCD display displays "Low". At the tenth minute, the green LED is off, the yellow LED is on, the LCD display displays "Medium" and the left exhaust fan is on.

In the second experiment, two cigarettes were burned, then placed on an ashtray and put into the simulation room. At the beginning of the experiment, before the fourth

minute, the LED lights off and the LCD display does not display smoke condition information. In the fourth minute, the green LED lights up and the LCD display displays "Low". At the seventh minute, the green LED is off, the yellow LED is on, the LCD display displays "Medium" and the left exhaust fan is on. In the twelfth minute, the yellow LED light is off, the red LED is on, the LCD display displays "High" and both exhaust fan are on.

In the third experiment, three cigarettes were burned, then placed on an ashtray and put into the simulation room. At the beginning of the experiment, before the third minute, the LED lights off and the LCD display does not display smoke condition information. In the third minute, the green LED lights up and the LCD display displays "Low". In the fifth minute, the green LED is off, the yellow LED is on, the LCD display displays "Medium" and the left exhaust fan is on. In the eighth minute, the yellow LED light is off, the red LED is on, the LCD display displays "High" and both exhaust fan are on.

In the fourth experiment, four cigarettes were burned, then placed on an ashtray and put into the simulation room. At the beginning of the experiment, before the second minute, the LED lights off and the LCD display does not display smoke condition information. In the second minute, the green LED lights up and the LCD display displays "Low". In the third minute, the green LED is off, the yellow LED is on, the LCD display displays "Medium" and the left exhaust fan is on. In the fifth minute, the yellow LED is off, the red LED is on, the LCD display displays "High" and both exhaust fan are on.

In the fifth experiment, five cigarettes were burned, then placed on an ashtray and put into the simulation room. At the beginning of the experiment, before the first minute, the LED lights off and the LCD display does not display smoke condition information. In the first minute, the green LED lights up and the LCD display displays "Low". In the second minute, the yellow LED light is on, the LCD display displays "Medium" and the left exhaust fan is on. In the third minute, the yellow LED is off, the red LED is on, the LCD display displays "High" and both exhaust fan are on.

In the five experiments conducted, the performance of the CO₂ gas concentration control system controlled by the Arduino UNO microcontroller can be analyzed through the output displayed by the LCD screen, LED light, and exhaust fan. The analysis is based

on measuring the voltage at the output electrode of the MQ-2 sensor. With the increase in the amount of cigarette smoke in a simulation room measuring length x width x height of 15 cm x 20 cm x 15 cm, which is provided with a ventilation hole of 3.5 cm in diameter, the output voltage of the MQ-2 sensor is increasing, which is indicated by a higher voltage value. The Arduino UNO microcontroller turns on the LED light, with the green color indicating low smoke concentration in the simulation room, the yellow indicating medium smoke concentration in the simulation room, and the red indicating high smoke concentration in the simulation room. In addition, the voltage value given by the MQ-2 sensor to the Arduino UNO microcontroller can make the Arduino UNO microcontroller process the display on the LCD display according to the smoke conditions in the simulation room, which displays "Low" information for low smoke concentration in the simulation room, "Medium" information for the smoke concentration currently in the simulation room, and "High" information for high smoke concentration in the simulation room. In addition to the LCD display, the voltage value given by the MQ-2 sensor to the Arduino UNO microcontroller can make the Arduino UNO microcontroller able to turn on one exhaust fan in the condition when the simulation room is quite thick with smoke, which is generally indicated by the green light off and the yellow light on, and turn on the two exhaust fan in the condition when the simulation room is very thick with smoke, which is generally indicated by the yellow light off and the red light on.

The measurement results on the Arduino UNO microcontroller pin A0 connected to the MQ-2 sensor are shown in Table 1. Measurement of the output voltage of the MQ-2 sensor using a multimeter connected to the Arduino UNO microcontroller's A0 pin, where previously the Arduino UNO microcontroller's A0 pin was extended through the use of a conductor rod soldered to the Arduino UNO microcontroller's A0 pin and extended (approximately 25 cm) to the output through ventilation holes that can make it easier for the multimeter pin to be connected to carry out voltage measurements, resulting in changes in voltage values as the smoke concentration increases in the simulation room. Based on the measurement results, it was found that the smallest voltage value that can be measured is 300 millivolt in Experiment 1 when one cigarette is burned to the sixth minute, and the largest voltage value that can be measured is 3620 millivolt in Experiment 5 when five cigarettes are burned to the fifteenth minute. Based on the MQ-2 sensor

datasheet, the maximum voltage value of which is $5.0\text{ V} \pm 0.1\text{ V}$, the test in this research has not yet reached the maximum output voltage of the MQ-2 sensor, which can still be tolerated.

Table 1. MQ-2 Sensor Output Voltage

Time (in minutes)	Vout MQ-2 Experiment 1 (in mV)	Vout MQ-2 Experiment 2 (in mV)	Vout MQ-2 Experiment 3 (in mV)	Vout MQ-2 Experiment 4 (in mV)	Vout MQ-2 Experiment 5 (in mV)
1	0	0	0	0	900
2	0	0	0	900	1300
3	0	0	560	1200	2600
4	0	320	750	2700	3120
5	0	460	1210	3080	3140
6	300	870	2300	3120	3190
7	450	1140	2350	3220	3230
8	630	1220	3140	3310	3250
9	860	1910	3220	3360	3290
10	1230	2320	3340	3380	3340
11	1560	2720	3350	3420	3420
12	1780	3140	3380	3440	3450
13	1820	3230	3400	3460	3480
14	1850	3360	3420	3480	3500
15	1910	3410	3440	3490	3620

The voltage measurement in Experiment 1 resulted in the smallest voltage value above 0 millivolt of 300 millivolt in the sixth minute and the largest voltage of 1910 millivolt in the fifteenth minute. The voltage measurement in Experiment 2 produces the smallest voltage value above 0 millivolt of 320 millivolt in the fourth minute and the largest voltage of 3410 millivolt in the fifteenth minute. The voltage measurement in Experiment 3 produces the smallest voltage value above 0 millivolt of 560 millivolt in the third minute and the largest voltage of 3440 millivolt in the fifteenth minute. The

voltage measurement in Experiment 4 produces the smallest voltage value above 0 millivolt of 900 millivolt in the second minute and the largest voltage of 3490 millivolt in the fifteenth minute. The voltage measurement in Experiment 5 produces the smallest voltage value above 0 millivolt of 900 millivolt in the sixth minute and the largest voltage of 3620 millivolt in the fifteenth minute. With the results of voltage measurements in five experiments, information was obtained that the more cigarettes were burned, which produced smoke in the simulation room, the voltage value issued by the MQ-2 sensor increased.

The CO₂ gas concentration in the simulation room was measured using a CO₂ gas meter [26, 27, 28] in each experiment. The results of measuring CO₂ gas concentrations are shown in Figure 7.

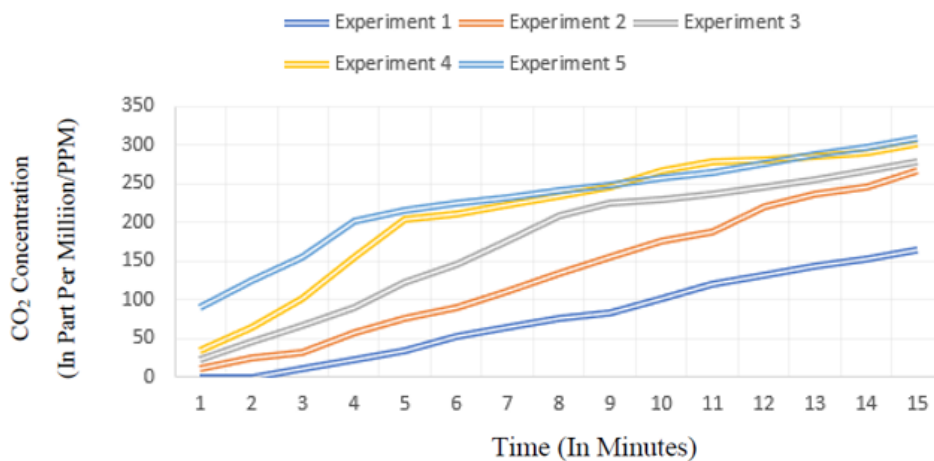

Figure 7. The CO₂ Gas Concentration

In Figure 7, the low concentration of CO₂ gas on the y-axis in the range of 50 to 100 ppm is indicated by a green LED turning on. This occurred between minutes 1 and 10 in Experiment 1, between minutes 1 and 6 in Experiment 2, between minutes 1 and 4 in Experiment 3, between minutes 1 and 3 in Experiment 4, and in minute 1 of Experiment 5. A yellow LED turning on indicates a medium concentration of CO₂ gas on the y-axis in the range of 100 to 200 ppm. This occurred in Experiment 1, between minutes 10 and 15 in Experiment 2, between minutes 7 and 15 in Experiment 3, between minutes 3 and 5 in Experiment 4, and between minutes 2 and 4 in Experiment 5. When the red LED turns on, there is a high concentration of CO₂ gas on the y-axis, in the range of 200 to 370

ppm. This occurred between minutes 12 and 15 in Experiment 2, between minutes 8 and 15 in Experiment 3, between minutes 6 and 15 in Experiment 4, and from minutes 5 to 15 in Experiment 5.

4 Conclusions

This research produces a conclusion about controlling the CO₂ gas concentration when detecting cigarette smoke in a simulation room. With the increase in the amount of cigarette smoke in a simulation room, the output voltage of the MQ-2 sensors is increasing. The CO₂ gas concentration rises in the simulation room as the amount of cigarette smoke increases. It can be concluded that as the number of cigarettes burned in the simulation room increases, the amount of cigarette smoke in the room increases, which causes the CO₂ gas concentration to increase and increases the voltage of the MQ-2 sensors required by the microcontroller to rotate the exhaust fan to control the CO₂ gas concentration. Based on Figure 7, the effectiveness of the exhaust fan rotation in controlling the CO₂ gas concentration detected by the MQ-2 sensor looks good where the CO₂ gas concentration can be controlled under 350 ppm.

Acknowledgements

Sri Hartanto is the main contributor to this paper, whose role is in designing electronic circuit, conceptualization, formal analysis, while Tri Ongko Priyono and Triono help in investigation and data validation. Thanks to all those who have helped with this research.

References

- [1] J. B. Sanger, L. Sitanayah, and V. D. Kumenap, Detection System for Cigarette Smoke, Proc. 4th International Conference on Information Technology, Information Systems and Electrical Engineering (ICITISEE), (2019) 145-149.

- [2] S. Panpaeng, P. Phanpeang, E. Metharak, Cigarette Smoke Detectors for Non-Smoking Areas in the Building, Proc. International Computer Science and Engineering Conference (ICSEC), (2018) 1-4.
- [3] Prajakta B, Volkan Y S, Masudul H I, Stephen T, and Edward S, Computation of Cigarette Smoke Exposure Metrics from Breathing, IEEE Transactions on Biomedical Engineering, 67(8) (2020) 1-5.
- [4] J. A. Stankovic, Research Directions for the Internet of Things, IEEE Internet of Things Journal, 1(1) (2014) 3-9.
- [5] H. Ping, J Wang, Z. Ma, Y. Du, Mini-review of application of IoT technology in controlling system agricultural products quality and safety, International Journal of Agricultural and Biological Engineering, 11(5) (2018) 35-45.
- [6] M. Muntjir, M. Rahul, H. A. Alhumyani, An Analysis of Internet of Things (IoT): Novel Architectures, Modern Applications, Security Aspects and Future Scope with Latest Case Studies, International Journal of Engineering Research & Technology (IJERT), 6(6) (2017) 422-448.
- [7] I. B. G. Purwania, I N. S. Kumara, and M. Sudarma, Application of IoT-Based System for Controlling system Energy Consumption, International Journal of Engineering and Emerging Technology, 5(2) (2020) 81-93.
- [8] C. Wang, M. Daneshmand, M. Dohler, X. Mao, R. Q. Hu, and H. Wang, Guest Editorial - Special issue on the internet of things (IoT): Architecture, protocols, and services, IEEE Sensor Journal, 13(10) (2013) 3505–3508.
- [9] R. A. Mouha, Internet of Things (IoT), Journal of Data Analysis and Information Processing, 9 (2021) 77-101.
- [10] R. Singh, A. K. Thakur, A. Gehlot, Akhilesh, Internet Of Things Based On Home Automation For Intrusion Detection, Smoke Detection, Smart Appliance And Lighting Control, International Journal of Scientific & Technology Research 8(12) (2019) 3702-3707.
- [11] M. A. Buchari, K. Exaudi, Rendyansyah, Aditya PP. Prasetyo, R. Zulfahmi, R. Passarella, Detection of Carbon Dioxide Levels in Smoker's Body, Proc. International Conference on Informatics, Multimedia, Cyber and Information System (ICIMCIS), (2019) 103-109.

- [12] S. Z. Yahaya, M. N. Mohd Zailani, Z. H. Che Soh, K. A. Ahmad, IoT Based System for Controlling system and Control of Gas Leaking, Proc. 1st International Conference on Information Technology, Advanced Mechanical and Electrical Engineering (ICITAMEE), (2020) 122-127, 2020.
- [13] T. S. Gunawan, I. R. H. Yaldi, M. Kartiwi, H. Mansor, Performance Evaluation of Smart Home System using Internet of Things, International Journal of Electrical and Computer Engineering (IJECE) 8(1) (2018) 400~411.
- [14] I. K. N. Trisnawan, A. N. Jati, N. Istiqomah, and I. Wasisto, Detection of Gas Leaks Using The MQ-2 Gas Sensor on the Autonomous Mobile Sensor, Proc. International Conference on Computer, Control, Informatics and its Applications, (2019) 177-180.
- [15] Somantri, R. F. Ridwanullah, Hendra, D. Safitri, Cigarette Smoke Detection System for Non-Smoking Areas Based on IoT and Face Recognition, Proc. 6th International Conference on Computing Engineering and Design (ICCED), (2020) 1-6.
- [16] S. Khan, K. Muhammad, S. Mumtaz, S. W. Baik, V. Hugo C. de Albuquerque, Energy-Efficient Deep CNN for Smoke Detection in Foggy IoT Environment, IEEE Internet of Things Journal, 6(6) (2019) 1-9.
- [17] M. Jin, N. Bekiaris-Liberis, K. Weekly, C. J. Spanos, and A. M. Bayen, Occupancy Detection via Environmental Sensing, IEEE Transactions on Automation Science and Engineering Journal, 15(2) (2018) 443–455.
- [18] I. Deshko, V. Tsvetkov, Sequential Methods and Algorithms, Journal of Physics Conference Series 2388(1) (2022) 1-5.
- [19] S. N. Rodionov, A Sequential Algorithm for Testing Climate Regime Shifts, Geophysical Research Letters, 31(L09204) (2004) 1-4.
- [20] S. A Ritonga, Syahwin, T. Haramain, Penerapan Algoritma Sekuensial pada Penyiraman Tanaman Otomatis Berbasis Arduino Uno R3, Blend Sains Jurnal Teknik, 1(1) (2022) 62-68.
- [21] Keshamoni, K., Hemanth, S, Smart Gas Level Monitoring, Booking & Gas Leakage Detector over IoT, Proc. IEEE 7th International Advance Computing Conference (IACC), (2017) 330-332.
- [22] Anoname, MQ-2 Semiconductor Sensor for Combustible Gas.

- [23] Montoya, J. M., and Chilo, J, RealTime Wireless Monitoring System of CO₂ and CH₄ in Juliaca-Perú, Proc. 10th IEEE International Conference on Intelligent Data Acquisition and Advanced Computing Systems: Technology and Applications (IDAACS), (2019) 464-467.
- [24] A. S. Ismailov, Z. Jo`rayev, Andijan, Study of Arduino Microcontroller Board, Science and Education" Scientific Journal, 3(3) (2022) 172-179.
- [25] L. Louis, Working Principle of Arduino and Using it as a Tool for Study and Research, Proc. International Journal of Control, Automation, Communication and Systems (IJCACS), (2018) 21-29.
- [26] A. Abdurrachman, I. Chandra, R. A. Salam, Rancang Bangun Alat Ukur Konsentrasi Gas CO₂ dan NO₂ untuk Pengamatan Emisi dari Pembakaran Sampah Rumah Tangga, e-Proceeding of Engineering, 7(1) (2020) 1342-1349.
- [27] S. Handayani, L. Umar, R. Setiadi, Pengembangan Deteksi Online Gas Karbondioksida Menggunakan CO₂ Meter Voltcraft Cm-100, JOM FMIPA, 2(2) (2015) 1-10.
- [28] Anoname, User's Guide CO₂ Monitor Model CO200, Extech Instruments Corporation (a FLIR company).